



OPAL 200AB

Air Blower Assemblies



- **Wall mount & integrated assembly designs**
- **Single or dual side operation**



- ***Lightweight design with heavy duty filter & pre-cleaner***
- ***Suitable for OPAL 100 and OPAL 200 application***
- ***Kit includes 6 metres air hose & couplings***
- ***Variety of single & three phase supply options***

“ Australian environmental technology ”

200AB Series - Technical Specifications

OPAL-ABI

Enclosure
Weight
Mounting
Access
Power Supply
Airflow

Designed for integration with OPAL 200 weather cover system, IP44 – rain proof
18.5 Kg
Below transceiver and retro mounting plates, using support brackets as supplied.
Hinged front cover - release clips, swing down
120 or 240vac, 50/60Hz, 6 ampere
73 cubic metres per hour @ 1013 mbar

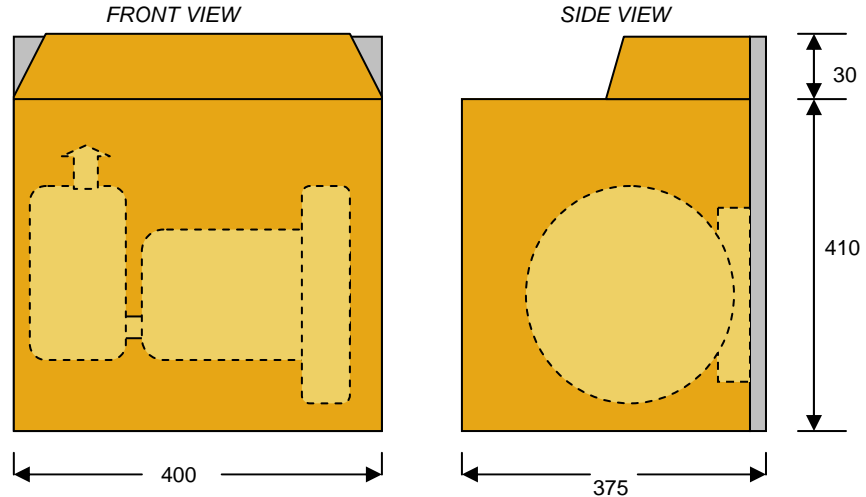

OPAL-ABW

Enclosure
Weight
Mounting
Access
Power Supply
Airflow

Wall mount type, IP44 – rain proof
19.4 Kg
Wall mount, via mounting straps (supplied). Hole centres 295W x 540H
Hinged front cover - release clips, swing down
120 or 240vac, 50/60Hz, 6 ampere
73 cubic metres per hour @ 1013mbar

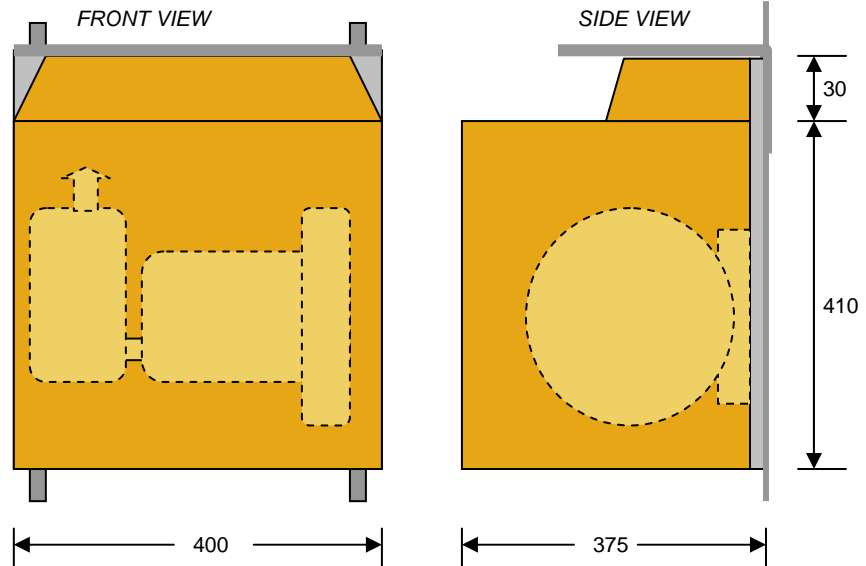

OPAL Environmental Pty Ltd

Unit 30 / 24 Anzac Avenue Smeaton Grange NSW 2567
Post Office Box 57 Cobbitty NSW 2570 Australia
Tel: (61) 2 4648 4500 Fax: (61) 2 4648 4055

www.opalenvironmental.com.au

LOCAL SALES & SERVICE